

AIR ELIMINATORS FOR WATER SYSTEMS AE20 (Carbon Steel)

DESCRIPTION

The AE20 carbon steel air eliminator removes air from cold, hot and superheated water systems and is also suitable for all liquids compatible with the construction, providing that their specific weight is no less than 0,75 kg/dm³.

This ball float type automatic air eliminator can be used in combination with other air elimination and separation systems or directly applied at high points in the piping

MAIN FEATURES

Corrosion resistant working parts.
Replaceable internal parts.

USE: Cold, hot and superheated water systems or other liquids compatible with the construction.

AVAILABLE MODELS: AE20-21.

SIZES: 1/2" to 1"; DN 15 to DN 25.

CONNECTIONS: Female threaded ISO 7 Rp.
Flanged EN 1092-1 PN40.
ANSI B16.5 Class 150 lb or 300 lb.
Special flanges upon request.

INSTALLATION: Horizontal or vertical installation (on request).
It must be installed with the float lever in an horizontal plane, so that it rises and falls vertically. It should be installed at the points of the plant where the air tends to collect.
The drain should be piped to a safe position.
See IMI – Installation and maintenance instructions.



APPLICATION LIMITS	
Min. liquid specific weight	0,75 kg/dm ³
Maximum working diff. pressure	21 bar

CE MARKING – GROUP 2 (PED – European Directive)	
PN40	Category
1/2" to 1"; DN 15 to 25	SEP

BODY LIMITING CONDITIONS		
FLANGED PN40/ANSI 300 lb *	FLANGED ANSI 150 lb**	RELATED TEMP.
ALLOWABLE PRESSURES	ALLOWABLE PRESSURES	
37,1 bar	15,4 bar	100 °C
33,3 bar	13,8 bar	200 °C
30,4 bar	12,1 bar	250 °C
27,6 bar	10,2 bar	300 °C

PMO – Max. operating press. 32 bar;

TMO – Max. operating temp. 200 °C;

* According to EN1092-1:2018;

** According to EN1759-1:2004;

Body limiting conditions PN40 or below, depending on the type of connections adopted. Rating PN40 for thread, SW and BW.

FLOW RATE CAPACITY (NL/h)													
MODEL	SIZE	DIFFERENTIAL PRESSURE (bar)											
		0,5	1	1,5	2	3	4	6	8	10	15	21	
AE20-21	1/2" to 1" DN 15 to 25	18	32	45	55	75	90	130	180	210	300	430	

Capacities shown refer to the capacity of air discharge at 15 °C, under atmospheric pressure.

If the temperature of the air differs from 15 °C, the discharge capacity can be corrected by multiplying it by: $\frac{288}{273 + T}$, where T is the actual temperature in °C.

It may be assumed that the temperature of the air is equal to the temperature of the water.

DIMENSIONS (mm)

SIZE	THREADED						PN16/40		ANSI 150 lb		ANSI 300 lb	
	A	B	C	D	H	WGT. (kg)	F	WGT. (kg)	F	WGT. (kg)	F	WGT. (kg)
1/2" – DN 15	95	178	23	128	1/4" NPT	5,2	150	6,7	150	6,2	150	7
3/4" – DN 20	95	178	23	128	1/4" NPT	5,2	150	7,4	150	6,6	150	8,2
1" – DN 25	95	178	23	128	1/4" NPT	5,2	160	7,8	160	7,4	160	9

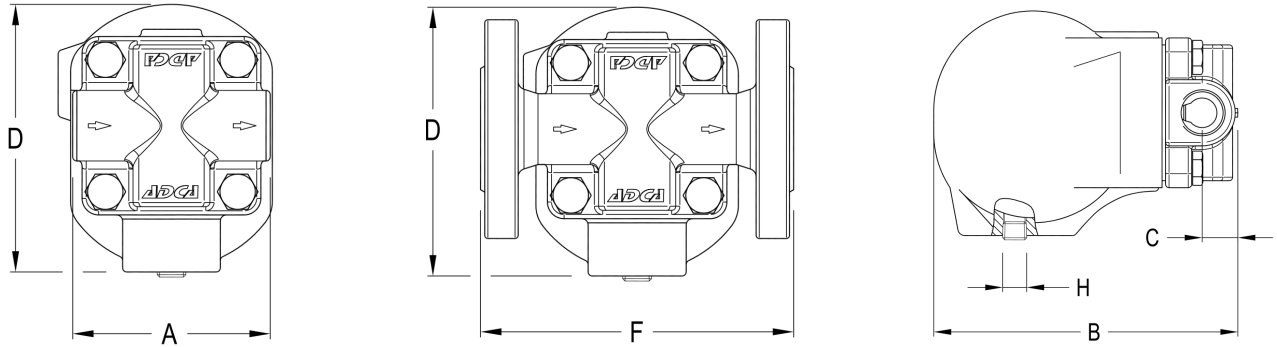

MATERIALS

POS. N°	DESIGNATION	MATERIAL
1	Body	GP240GH / 1.0619
2	Cover	GP240GH / 1.0619
3	* Gasket	Stainless steel / Graphite
4	* Seat	AISI 410 / 1.4006
5	* Valve	Viton
		AISI 440C / 1.4125
6	* Lever	AISI 304 / 1.4301
7	* Float	AISI 304 / 1.4301
8A	** Compression fitting	Stainless steel or Steel Fe/Zn
9	Bolts	Steel 8.8

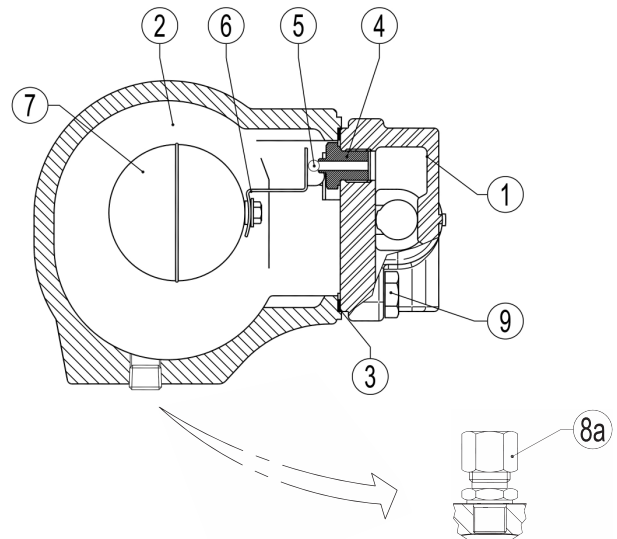

* Available spare parts; ** Optional, against extra price;

TYPICAL INSTALLATION

